



## **FTT**

### **Tray Washer**



**Spare Parts**  
**Pièces Détachées**  
**Ersatzteile**  
**Onderdelen**

**Contents**

Transport system page 1.....	3
Transport system page 2.....	4
Wash module 1400.....	5
Strainers & Drains.....	6
Tank heating & Float switch.....	7
Wash system.....	8
Blower & Rinse.....	9
Booster & heating.....	10
Booster 0.5m2 hot water & steam.....	11
Tank heating hot water & steam.....	12
Panels & insulation wash modu1400.....	13
Dryer module 850.....	14
Panels & insulation dryer module 850.....	15
Condenser.....	16
Exhaust extraction - Fan.....	17
Tray Stacker.....	18
Tray stacker with buffer stacker.....	19

**Inhalt**

Transportsystem Blatt 1.....	3
Transportsystem Blatt 2.....	4
Waschmodul 1400.....	5
Sieb & Ablauf.....	6
Tankeizung & Schwimmer-Schalte.....	7
Waschsystem.....	8
Vorausblasung & Spülung.....	9
Durchlauferhitzer & beheizt.....	10
Durchlauferhitzer 0,5m2 HW / Dampf.....	11
Tankheiyung HW / Dampf.....	12
Verkleidungen / Isolation Waschmodul 1400.....	13
Trockenmodul 850.....	14
Verkleidungen / Isolation Trockenmodul 850.....	15
Kondensator.....	16
Wrasenabyug - Ventilator.....	17
Abstapelung.....	18
Abstapelung mit Zwischenstapel-Ein ichtung.....	19

**Sommaire**

System de transport page 1.....	3
System de transport page 2.....	4
Module de levage 1400.....	5
Filtres - Vidange.....	6
Chauffage du bac & Interrupteur à flotteur.....	7
System de lavage.....	8
Pre-soufflage & Rincage.....	9
Chaudière électrique.....	10
Chaudière 0,5m2 eau chaude & Vapeur.....	11
Chaudière du bac eau chaude & Vapeur.....	12
Habillage & Isolation module de lavage 1400.....	13
module de sechage 850.....	14
Habillage & Isolation module de sechage 850.....	15
Condenseur.....	16
Extraction des buées - Ventilateur.....	17
D'extraction system des plateaux.....	18
Empilage de plateaux (final et intermédiaire) .....	19

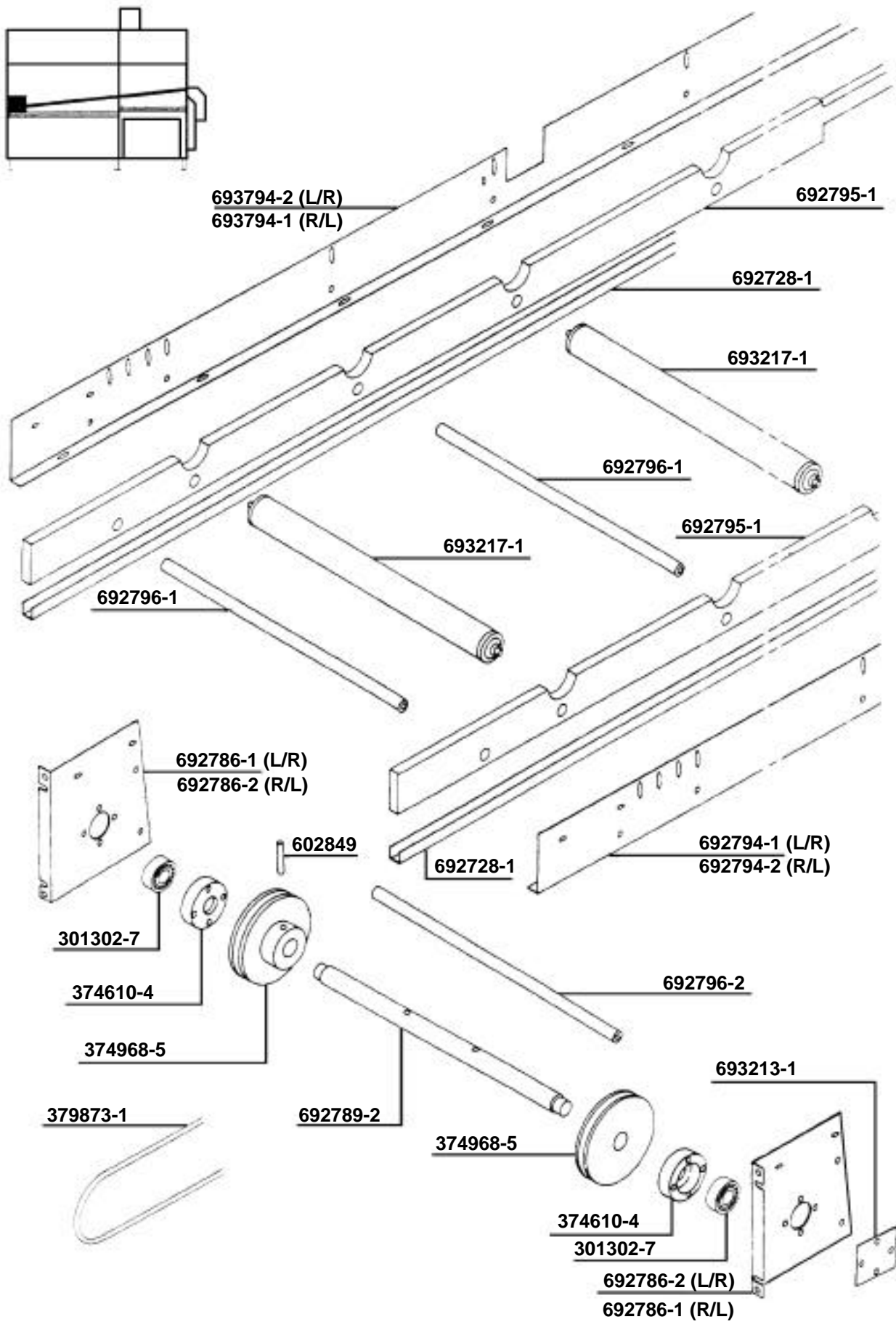

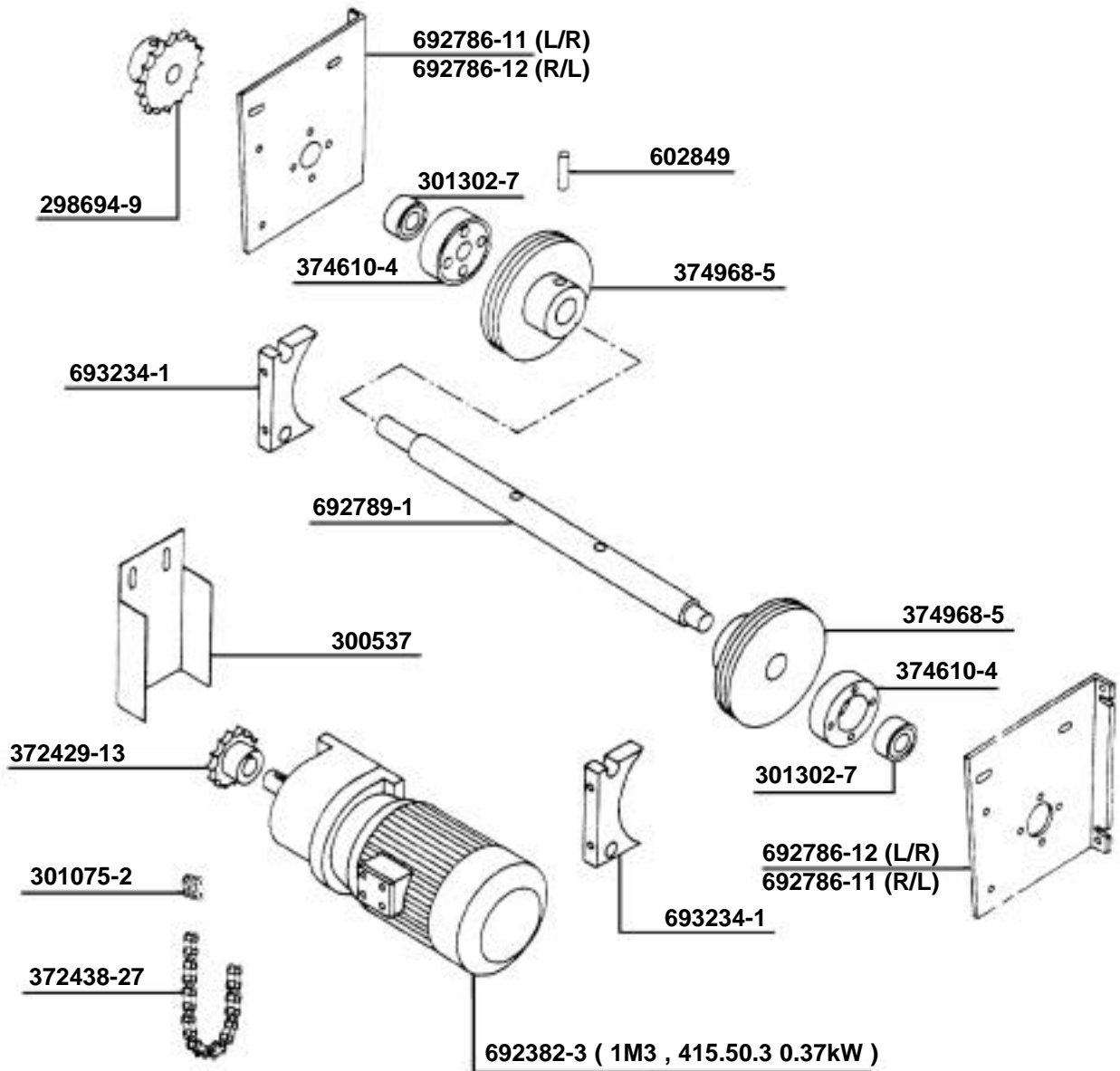
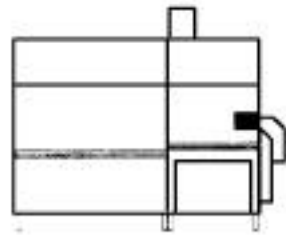

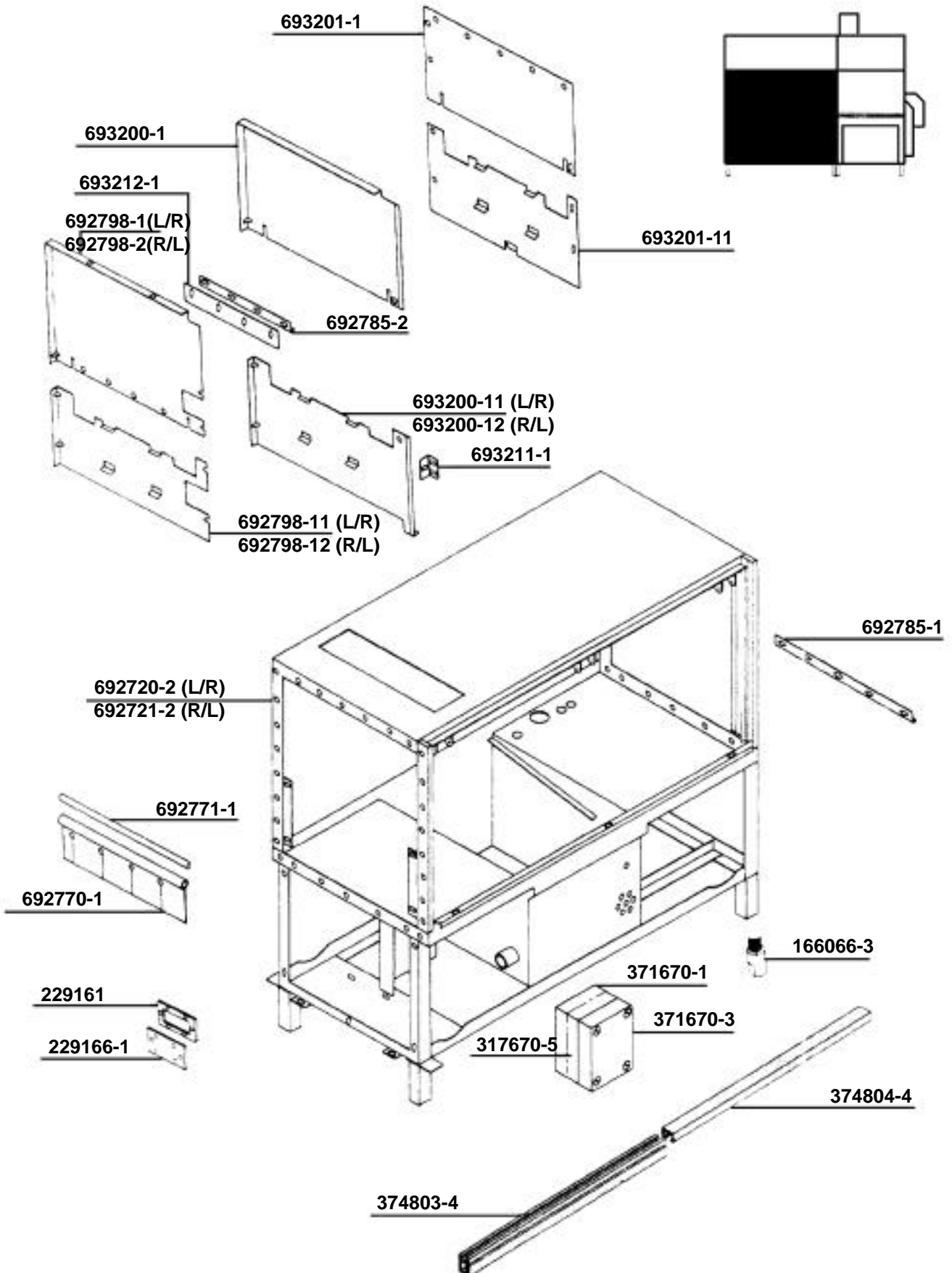

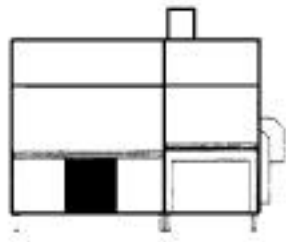

692774-1

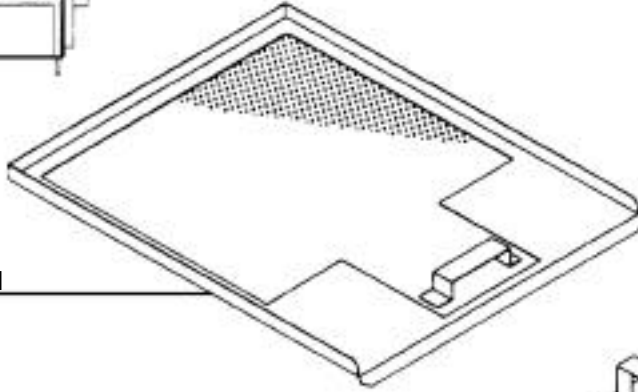

229400

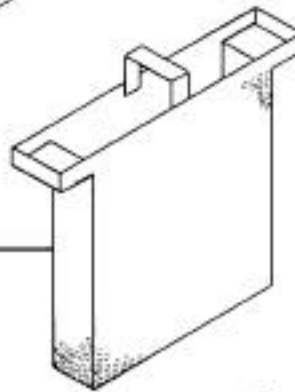

380098

230346-2



67500-15



226558-1

226556



229419

229394

229566

229153

229155



380096



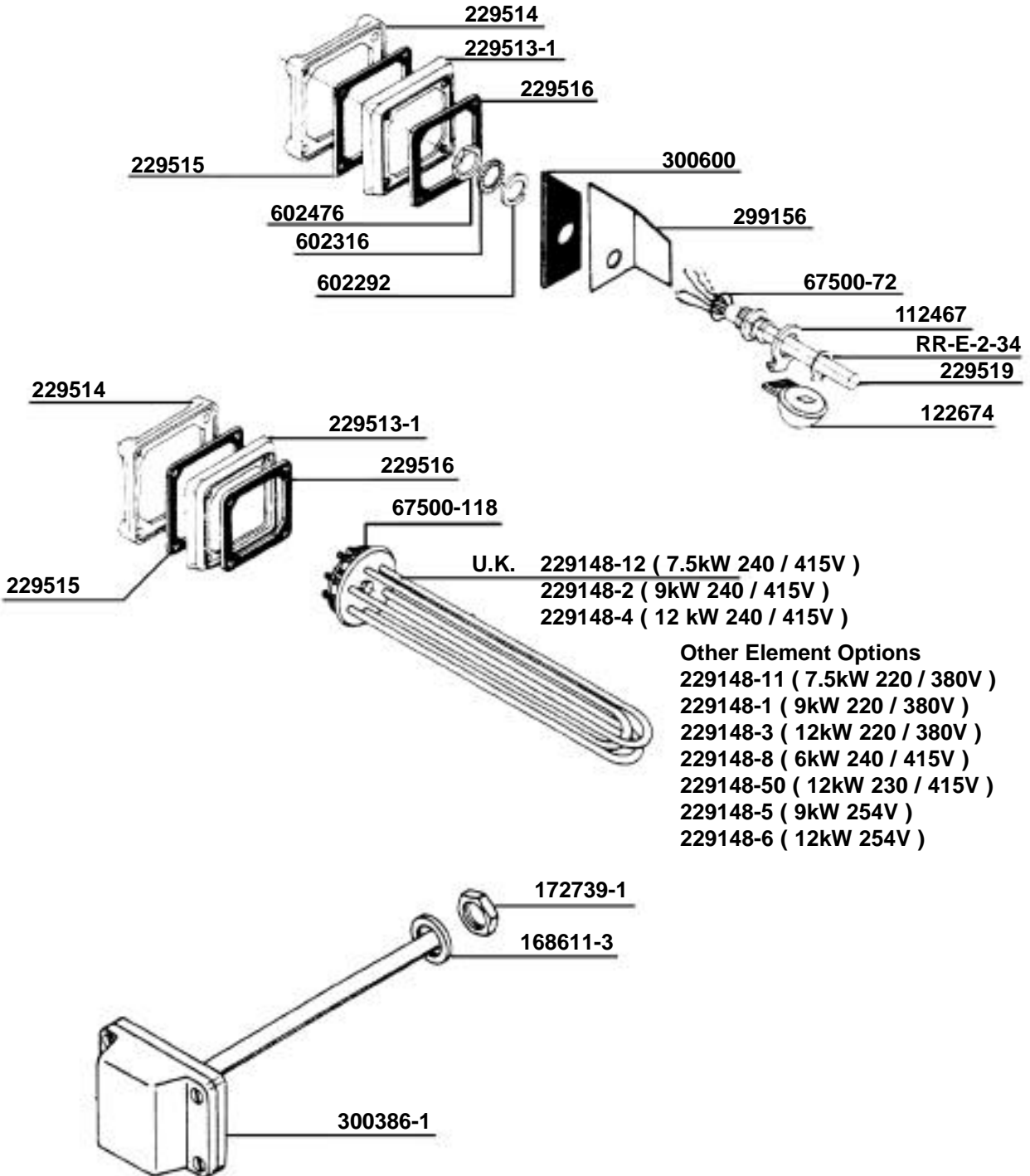
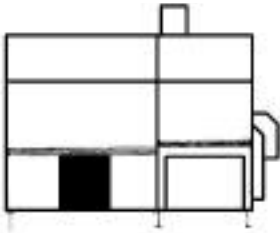

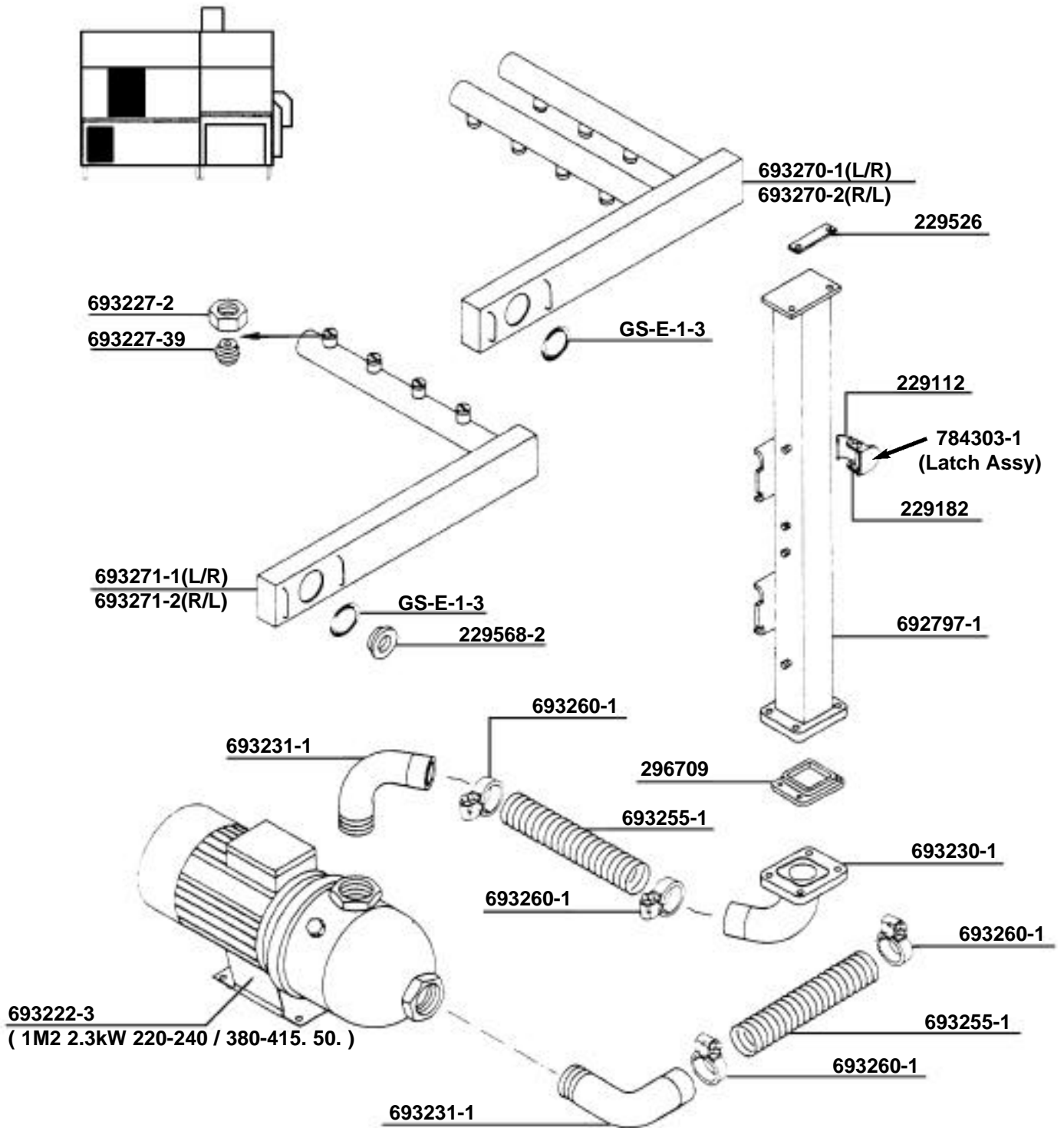



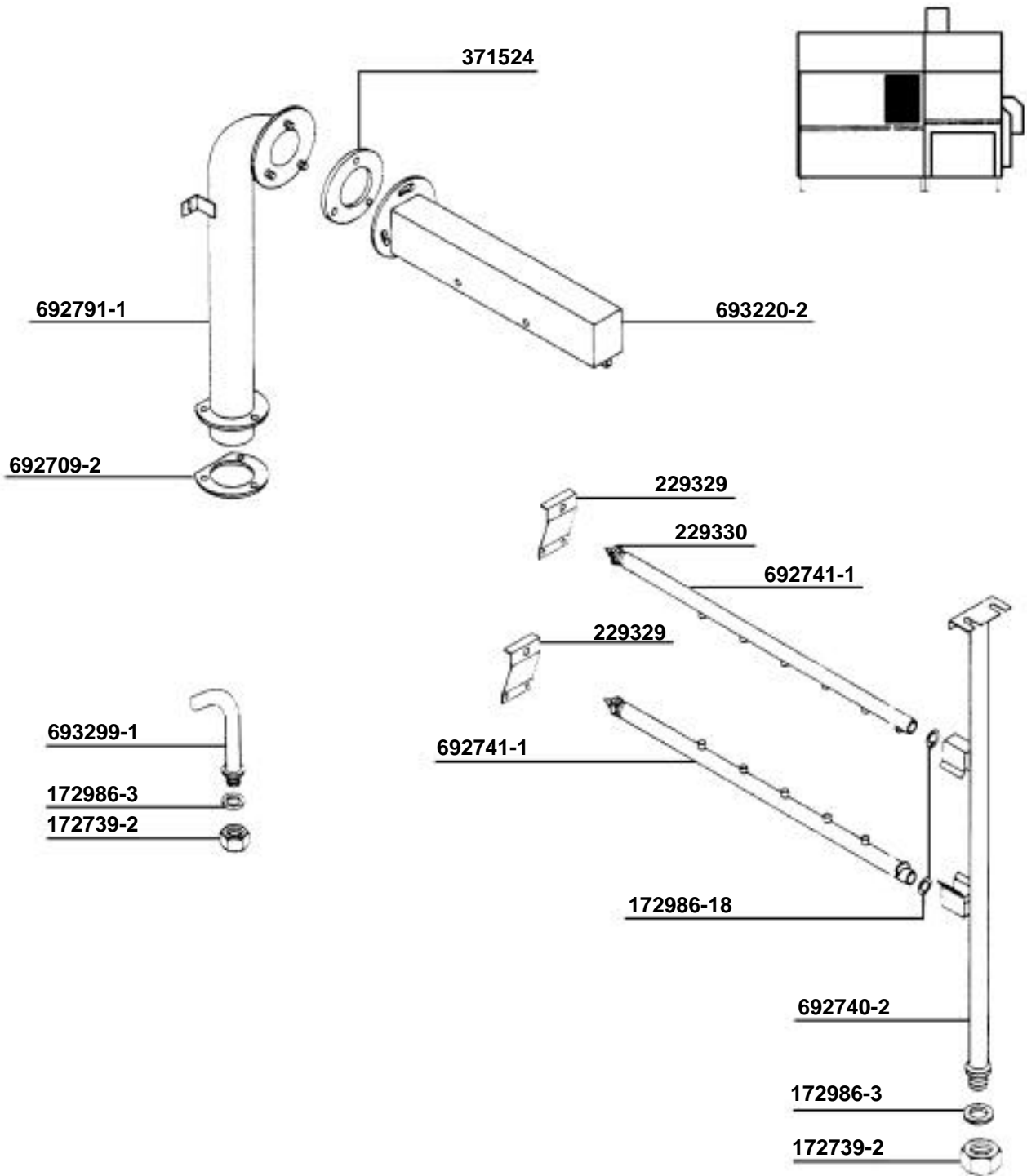

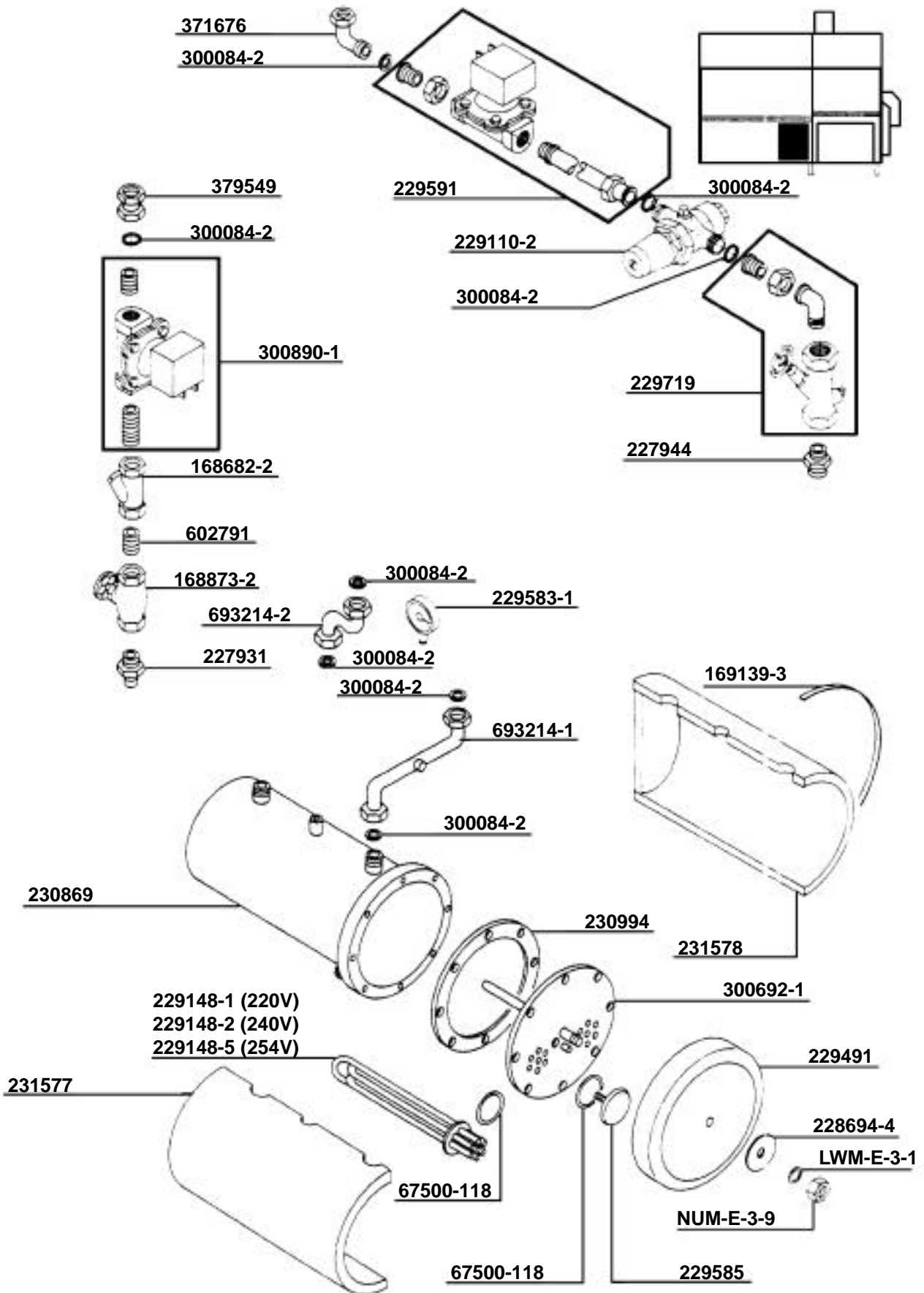

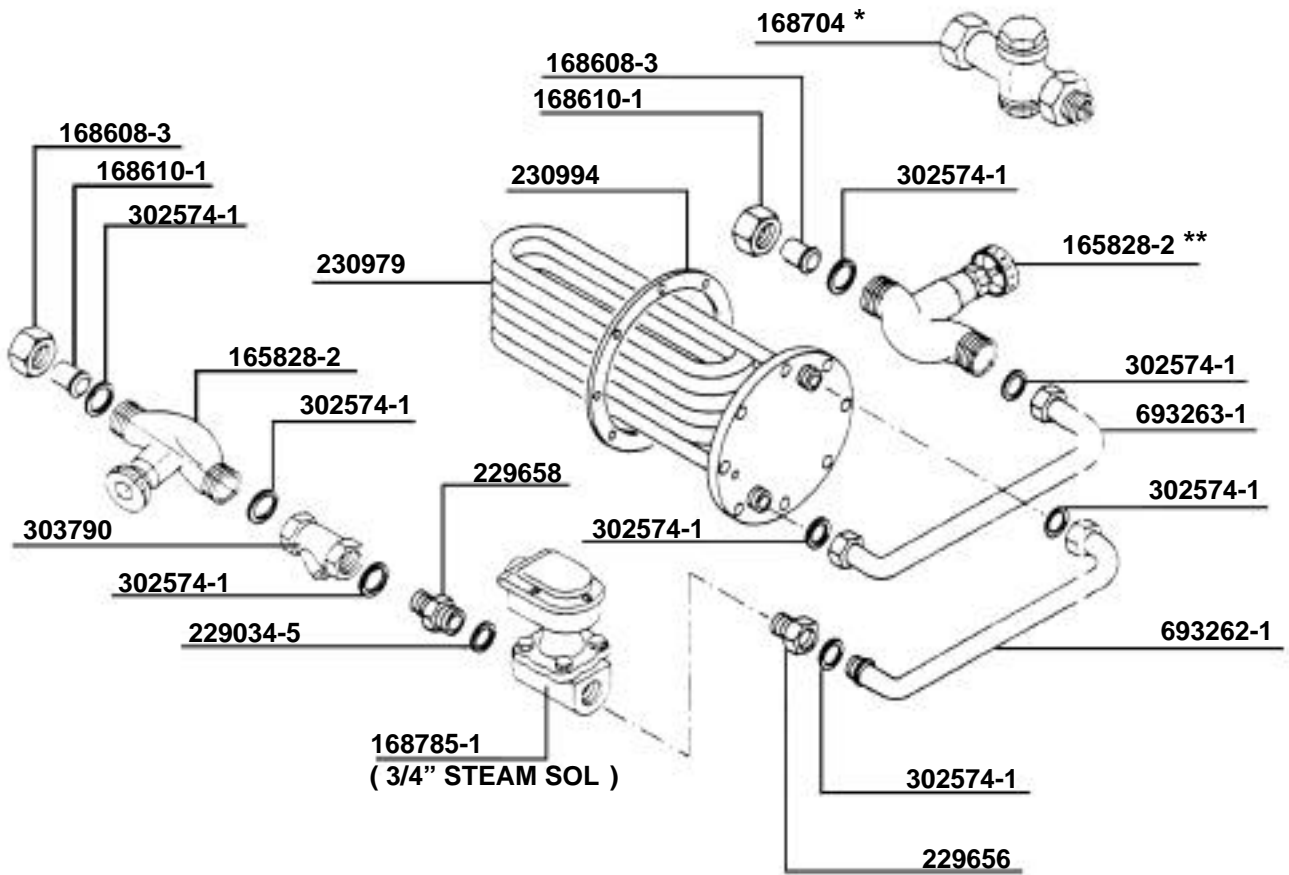
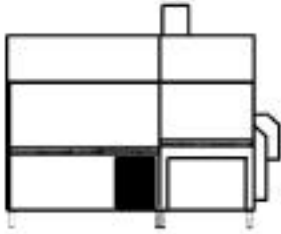

\*\* STEAM  
 VAPEUR  
 DAMPF  
 STOOM

\*\* HOT WATER  
 EAU CHAUDE  
 HEIBWASSER  
 HEET WATER

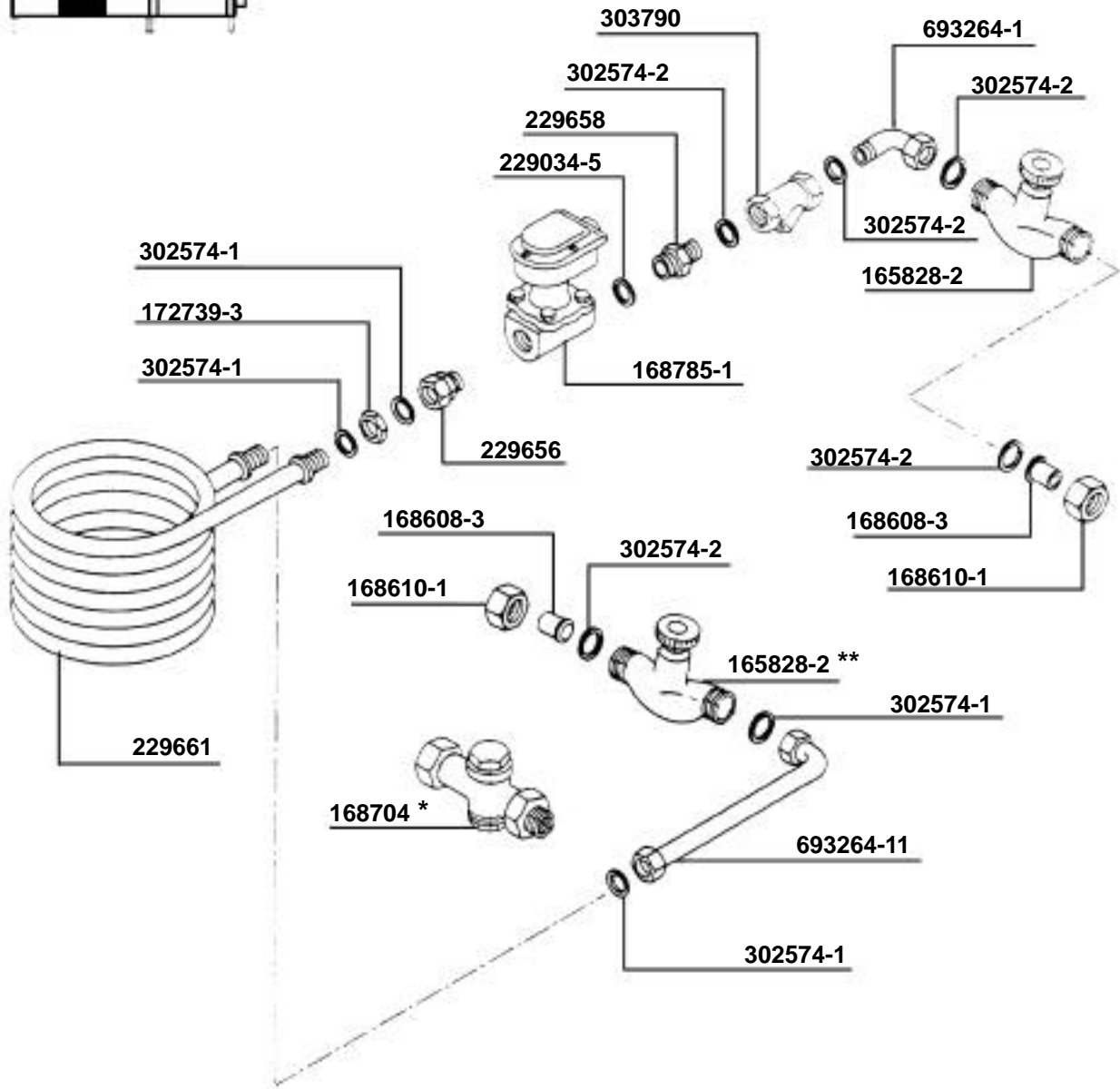
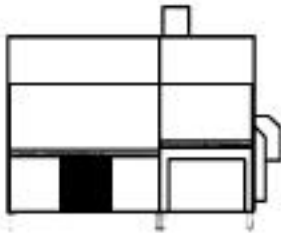

\*\* STEAM  
 VAPEUR  
 DAMPF  
 STOOM

\*\* HOT WATER  
 EAU CHAUDE  
 HEIBWASSER  
 HEET WATER

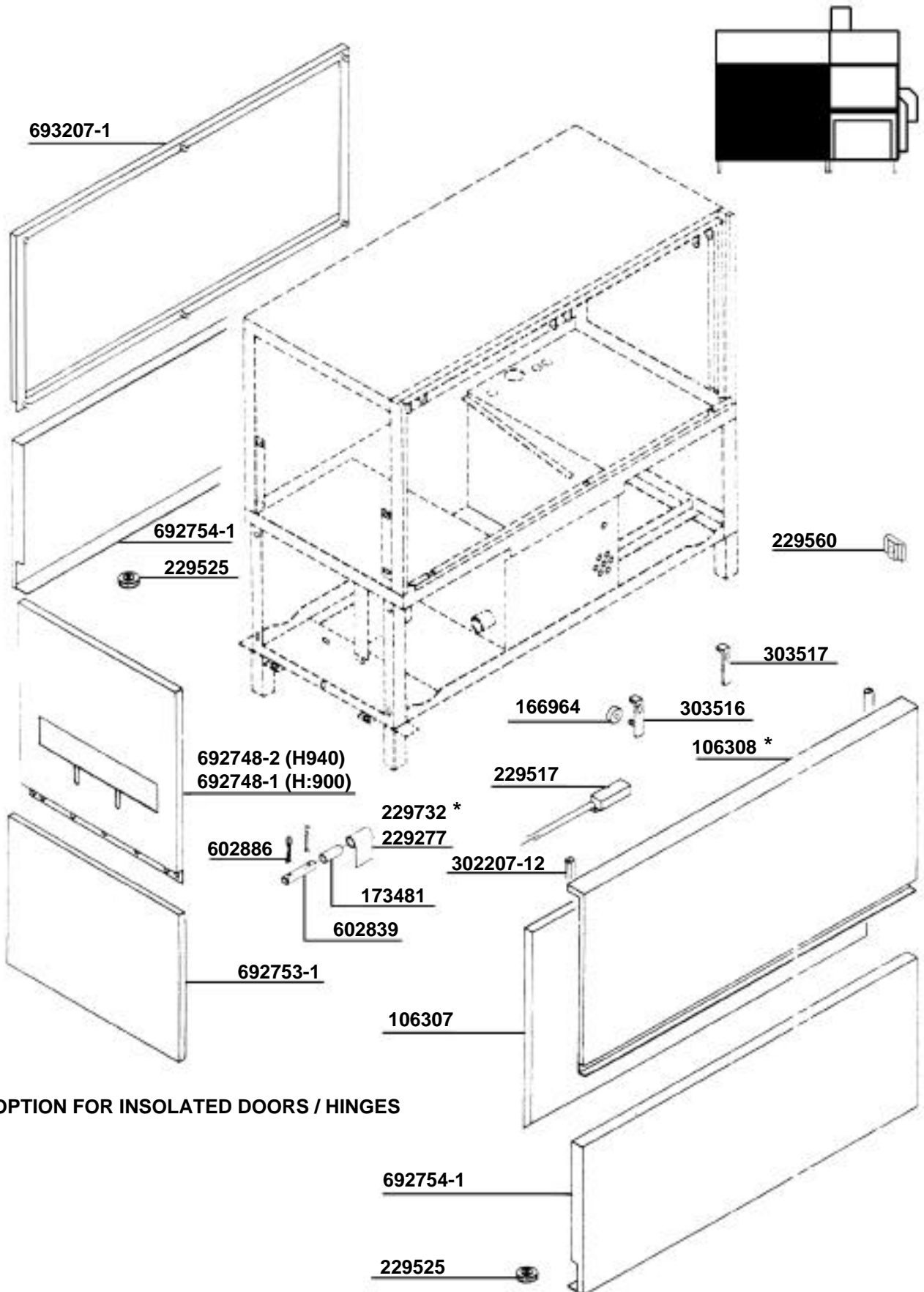

\* OPTION FOR INSOLATED DOORS / HINGES

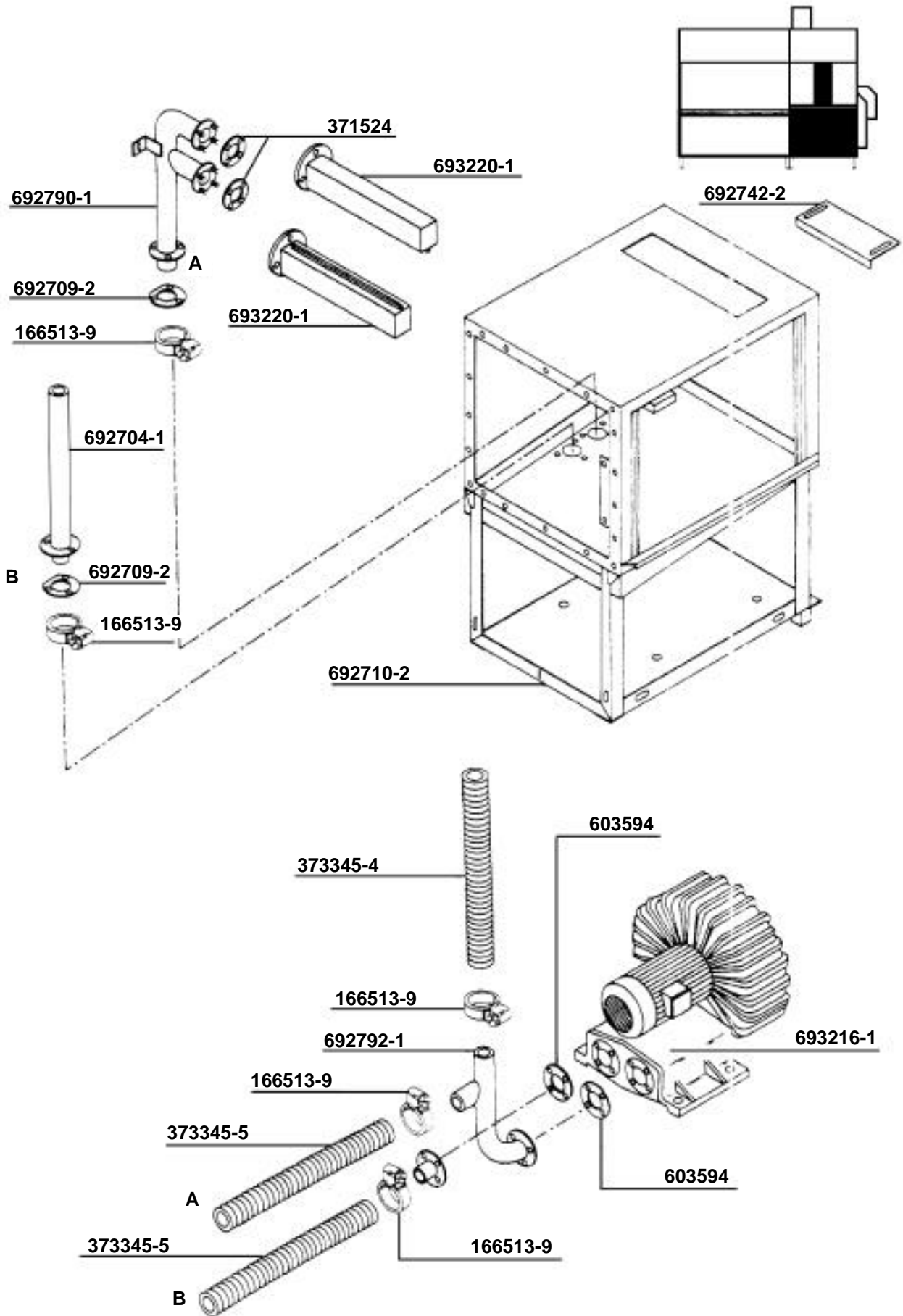

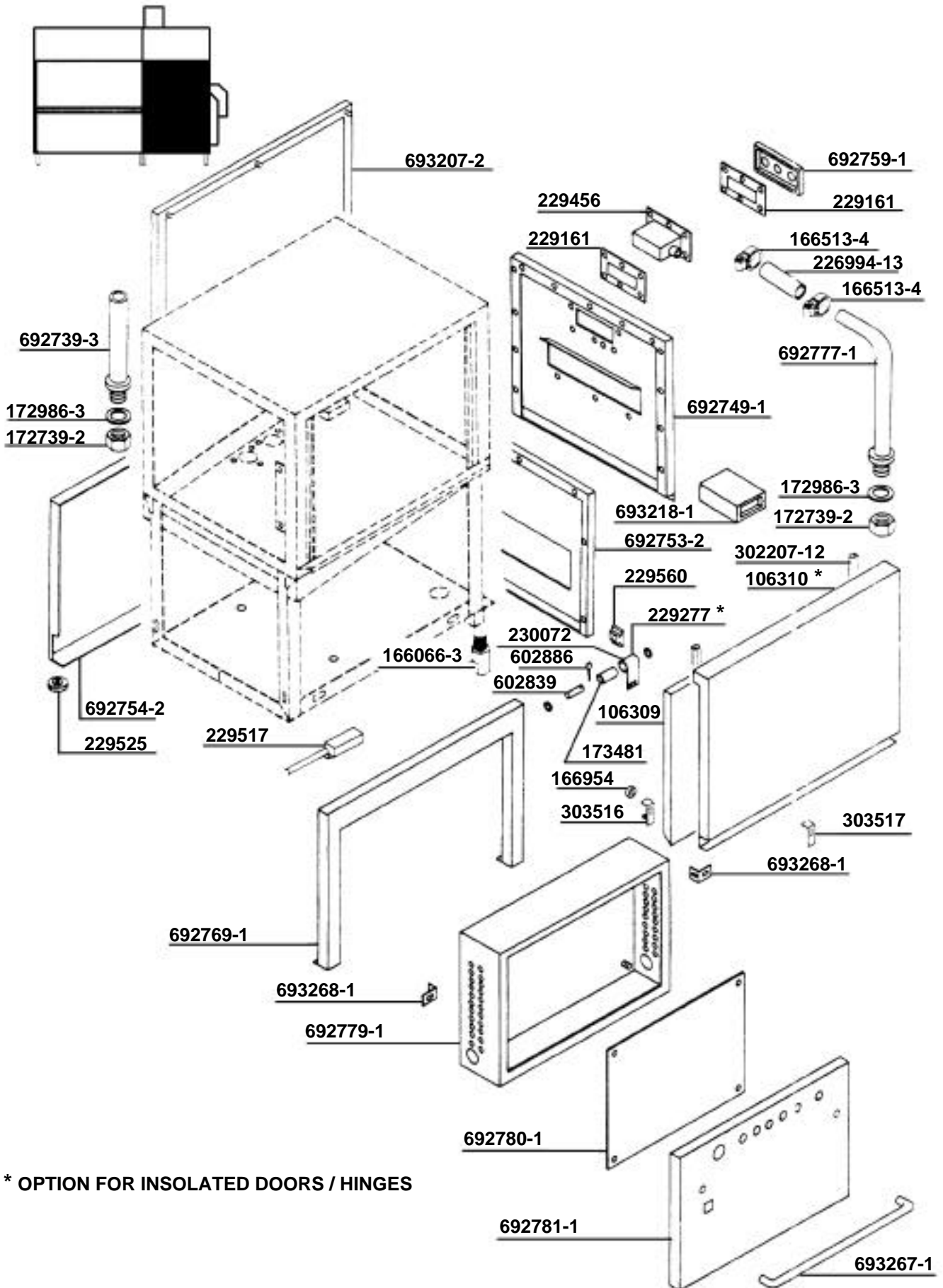

\* OPTION FOR INSOLATED DOORS / HINGES

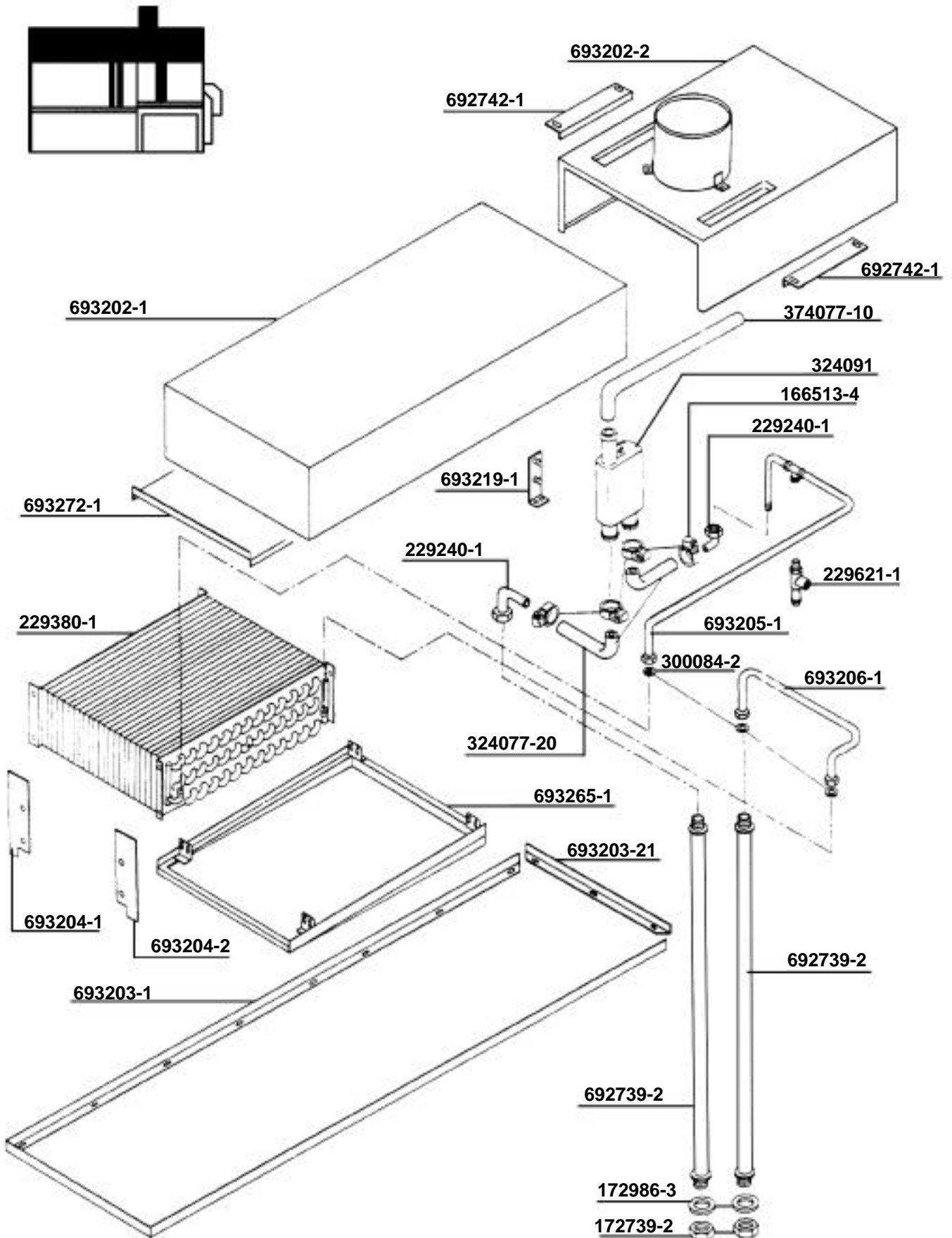



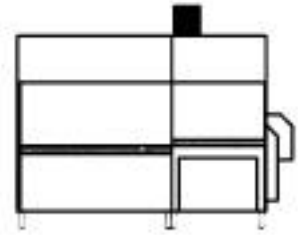
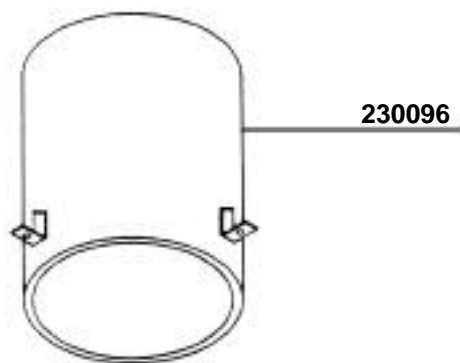
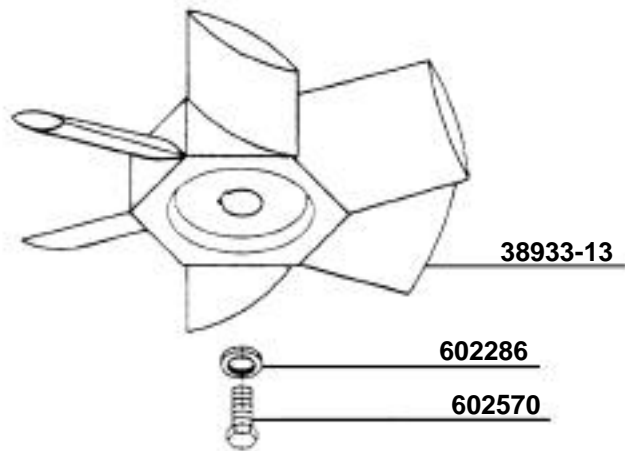
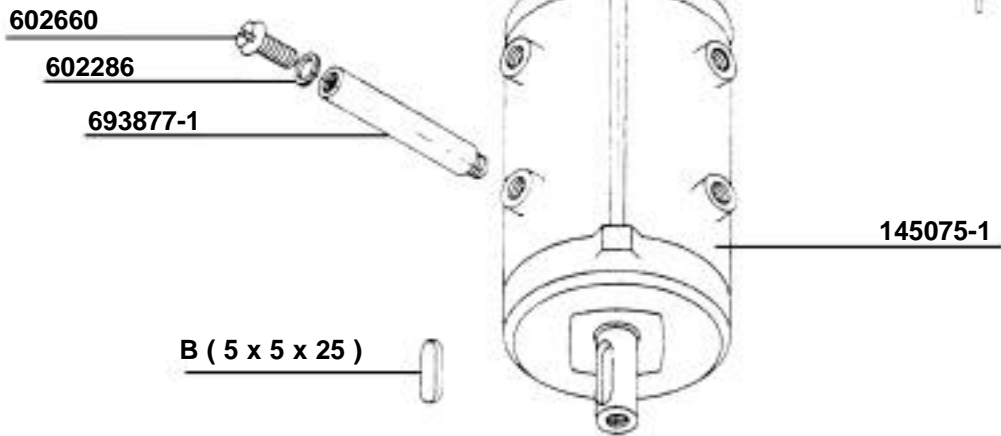

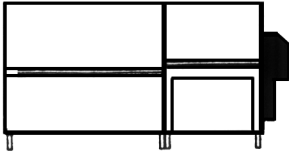

OHNE KLAPPTISCH  
WITHOUT FLAP TABLE  
SANS TABLE PLIANTE

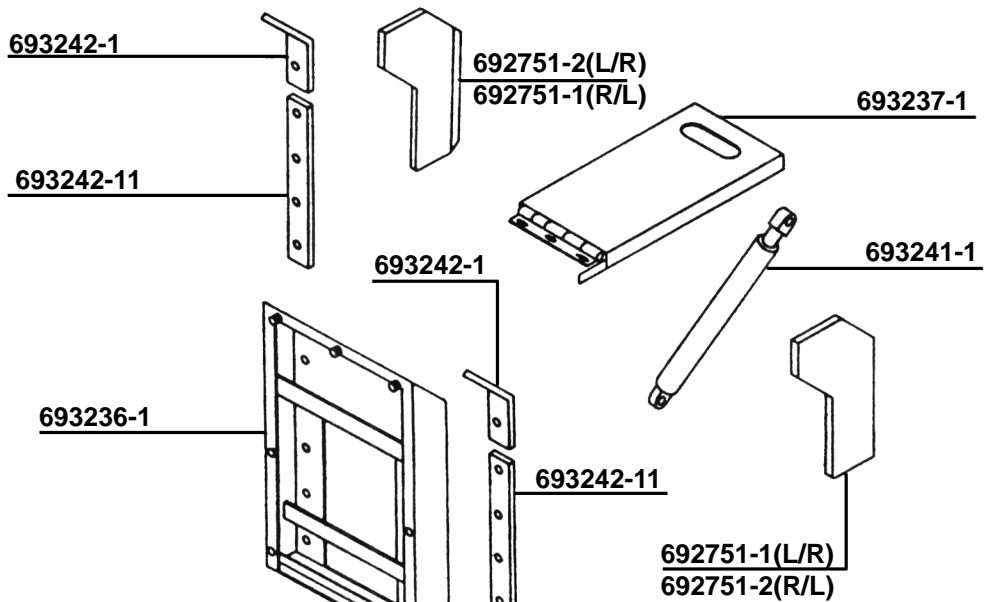
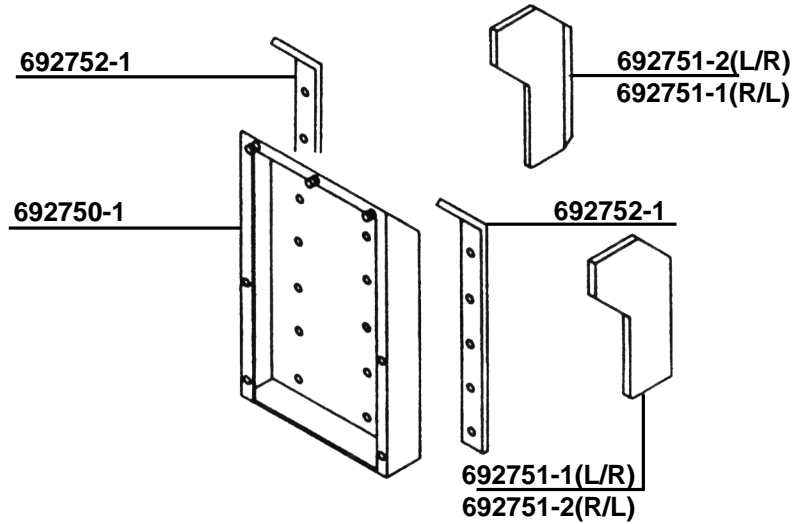

MIT KLAPPTISCH  
WITH FLAP TABLE  
AVEC TABLE PLIANTE

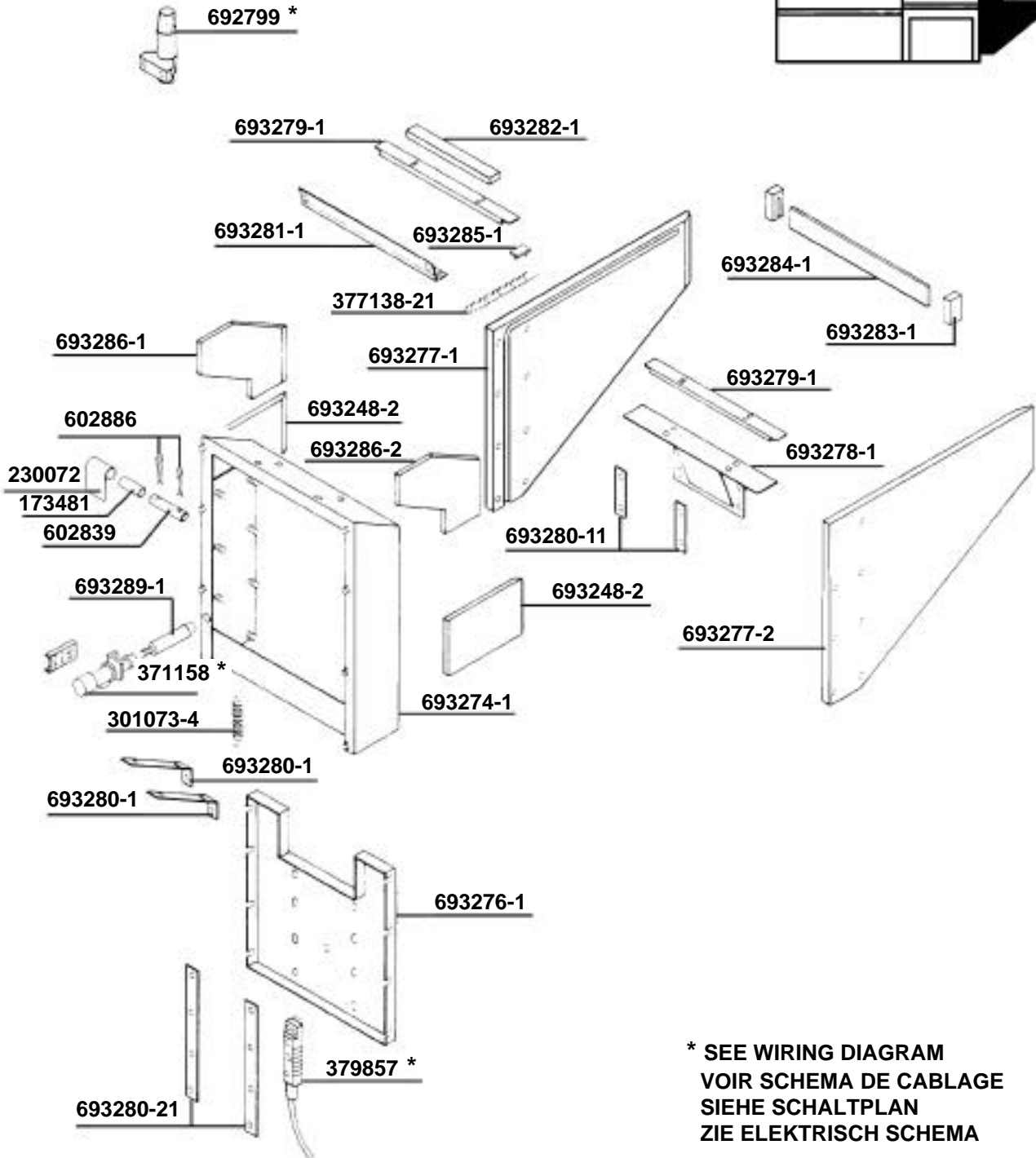
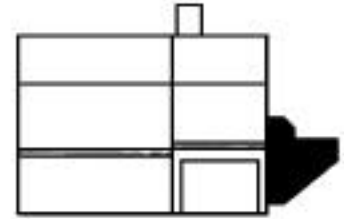

\* SEE WIRING DIAGRAM  
 VOIR SCHEMA DE CABLAGE  
 SIEHE SCHALTPLAN  
 ZIE ELEKTRISCH SCHEMA